



Pelletizer
PT-G100E - duodrive



Pelletizer PT-G100E - duodrive

ergonomic

- touch panel with easy-to-read, bright color display
- all controls are mounted in sight and handle height
- setting of speed and cutting length via arrow keys or direct input
- Display of the current utilization for feeder and cutting unit drive
- plain text fault display with remanent fault memory
- optional interface to a higher-level controller (Industry 4.0 ready)

variable

- two speed ranges
15-60 m / min / 22.5-90 m / min
- two variable cutting length ranges
1,5-3,0 mm / 2,0-4,0mm
- two operating sides
left / right (mirror image)
- two sizes for the cutting unit drive
3,0 kW / 5,5 kW
- Rotary cutters with 32 teeth, hardened tool steel or tungsten carbide
- optionally with noise insulation hood

powerful

- draw-in section with separate drive motor and frequency converter
- pneumatic roller pressing with sensitive regulation and pressure indication
- cutting section drive with powerful motor and frequency converter (short-term overload capacity up to 175%)

The pelletizer PT-G100E - duodrive is thus optimally equipped for the flexible production of compounds or masterbatches from a wide variety of products.



Operating panel



Ease of use and comfort of use as a profitable investment in operational safety, flexibility and product quality.



Data / Dimensions:

Pelletizer		PT-G100E
Working width	[mm]	100
No. of strands		max. 20
Throughput range	[kg/h]	max. 650
Drive power	[kW]	0,55-3,0 / 5,5
Velocity	[m/min]	15-60 / 22,5-90
Cutting length	[mm]	1,5-3,0 / 2,0-4,0
Cutting tool mat.		S01 / H02
Roller material		E01 / S02
Roller pressure		pneumatically
Sound level	[dbA]	<= 85
Weight	[kg]	500

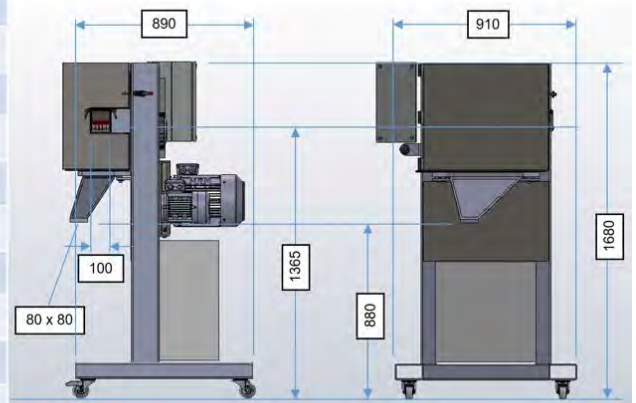

Throughput rates:

Pelletizer		PT-G100E-0,55/3,0		PT-G100E-0,55/5,5		
Velocity range [m/min]		15 - 60	22,5-90	15 - 60	22,5 - 90	
Produkte	[g/cm ³]	Strands	Throughput [kg/h]	Strands	Throughput [kg/h]	
PE/PP	0,92	12	281	20	468	702
PS/ABS/SAN	1,05	12	321	20	534	802
ABS/PC	1,07	12	327	20	545	817
PA	1,13	12	345	20	575	863
PC/ABS	1,18	12	360	20	601	901
PC	1,20	12	366	20	611	916
MB P40	1,30	12	397	20	662	992
PBT/PET	1,33	9	305	15	508	761
PA GF30	1,36	9	311	15	519	779
PA GF50	1,56	9	357	15	595	893
PBT GF50	1,72	9	394	15	657	985
FEP/PFA (PTFE)	2,15	9	492	15	821	1231

The stated throughput capacities are based on a strand diameter of 3.0 mm, the stated solids density of the respective plastic and maximum speed of the pelletizer. This does not take account of the procedural limits of the plastics to be processed.

Of course, the pelletizer could be completed with a suitable cooling trough, air knife and sifter forming a complete pelletizing line. The adaption of our equipment to existing pelletizing lines, as well as the delivery of special customized machinery will be executed flexible, quick and affordable.



About us:

The PT Maschinenbau GmbH is a privately owned company, located in southern Germany. As specialists in strand pelletizing we deliver our products from here to customers throughout whole Europe and worldwide.

We bundle up the core competencies for design, engineering and construction of our products. For the further provision of services we complement our abilities us by using a proven network of suppliers and service providers. We prefer generating our products by using local and European suppliers.



During decades of working in this business area we have gained a comprehensive experience, derived from countless projects with notable customers in all industry sectors and countries. Based on this know-how, with a long lasting and well-rehearsed team, we generate proven, reliable and durable solutions for our customers.

Scope of products:

Cooling				Drying		Cutting	Sifting
Cooling trough	Cooling belt	Strand conveyance	Water circulation	Air wipe	Air knife	Pelletizer	Sifter
PT-K150	PT-B100	PT-C100	PT-W20	PT-D50		PT-G50E	PT-S150
PT-K200	PT-B200	PT-C200	PT-W40	PT-D100		PT-G100E	PT-S300
PT-K250	PT-B300	PT-C300	PT-W60	PT-A75		PT-G120D	PT-S400
PT-K400			PT-W90	PT-A150		PT-G220D	PT-S400-DD
PT-K600			PT-W120	PT-A300		PT-G320D	PT-S550-DD
PT-K800			PT-W150	PT-A400			
				PT-A600			

PT Maschinenbau GmbH
Schafweide 3
D-63762 Grossostheim

Telefon: +49-(0)6026-95180-04
Telefax: +49-(0)6026-95180-05
eMail: office@pt-maschinenbau.com

Information and illustrations refer to the date of printing.
Subject to change. Version 2.1 - 2018-01